

**DIECI**



**PEGASUS 400°**

**38.16 | 40.18**



**dieci.com**

## PRESTAZIONI

Modello macchina	PEGASUS 38.16 - 400°	PEGASUS 40.18 - 400°
Portata massima	3800 kg (8378 lb)	4000 kg (8818 lb)
Altezza massima di sollevamento	15,70 m (51,5 ft)	18,00 m (59,1 ft)
Sfilo massimo orizzontale	13,40 m (44 ft)	15,30 m (50,2 ft)
Angolo di brandeggio forche	133°	133°
Forza di strappo	5700 daN (12814 lbf)	5700 daN (12814 lbf)
Forza di traino	7300 daN (16411 lbf)	7300 daN (16411 lbf)
Pendenza massima superabile	40%	40%
Massa a vuoto	13200 kg (29101 lb)	13700 kg (30203 lb)
Velocità massima (riferita a ruote con diametro massimo ammesso)	25 km/h (15,5 mph)	25 km/h (15,5 mph)

## BRACCIO

Modello macchina	PEGASUS 38.16 - 400°	PEGASUS 40.18 - 400°
Sollevamento	17,4 s	20,6 s
Discesa	12,6 s	14,2 s
Uscita	34,2 s	26,0 s
Rientro	21,9 s	17,0 s
Brandeggio avanti	3,9 s	3,8 s
Brandeggio indietro	2,4 s	2,0 s

## MOTORE

Modello macchina	PEGASUS 38.16 - 400°	PEGASUS 40.18 - 400°
Marca	Kubota	Kubota
Potenza nominale	73,4 kW (98 HP)	73,4 kW (98 HP)
@rpm	2600 rpm	2600 rpm
Funzionamento	4 tempi	4 tempi
Iniezione	Meccanica	Meccanica
Numero e disposizione cilindri	4, Verticali in linea	4, Verticali in linea
Cilindrata	3769 cm <sup>3</sup> (230 in <sup>3</sup> )	3769 cm <sup>3</sup> (230 in <sup>3</sup> )
Consumo	231 g/kWh (380 lb/Hp h)	231 g/kWh (380 lb/Hp h)
@rpm	2600 rpm	2600 rpm
Normativa emissioni	Stage IIIA/Tier 3	Stage IIIA/Tier 3
Sistema di raffreddamento	Liquido	Liquido
Aspirazione	Turbo compressore	Turbo compressore

## PONTI DIFFERENZIALI

Modello macchina	PEGASUS 38.16 - 400°	PEGASUS 40.18 - 400°
Tipo assali	2 sterzanti, con 4 riduttori epicicloidali	2 sterzanti, con 4 riduttori epicicloidali
Tipi di sterzata	4 ruote / trasversale / 2 ruote	4 ruote / trasversale / 2 ruote
Assale anteriore	Rigido	Rigido
Assale posteriore	Oscillante	Oscillante
Frenatura di servizio	A bagno d'olio con servofreno su assale anteriore e posteriore con impianto idraulico sdoppiato	A bagno d'olio con servofreno su assale anteriore e posteriore con impianto idraulico sdoppiato
Frenatura di stazionamento	Ad azionamento negativo con comando elettrico	Ad azionamento negativo con comando elettrico

## IMPIANTO IDRAULICO

Modello macchina	PEGASUS 38.16 - 400°	PEGASUS 40.18 - 400°
Tipo pompa idraulica	Pompa ad ingranaggi doppia con sistema "Energy Saving"	Pompa ad ingranaggi doppia con sistema "Energy Saving"
Portata pompa idraulica	135 L/min (35,7 gal/min)	135 L/min (35,7 gal/min)
Pressione massima di esercizio	23,0 MPa (3336 psi)	23,0 MPa (3336 psi)
Comando distributore	Joystick 5in1 proporzionale	Joystick 5in1 proporzionale
Tipo distributore	Idraulico a 5 sezioni servocomandato a controllo elettronico, proporzionale "Load Sensing" con "Flow Sharing", 5 movimenti contemporanei	Idraulico a 5 sezioni servocomandato a controllo elettronico, proporzionale "Load Sensing" con "Flow Sharing", 5 movimenti contemporanei

## RIFORMIMENTI

Modello macchina	PEGASUS 38.16 - 400°	PEGASUS 40.18 - 400°
Impianto idraulico (totale)	270,0 L (71,33 gal)	270,0 L (71,33 gal)
Serbatoio gasolio	180,0 L (47,55 gal)	180,0 L (47,55 gal)

## TRASMISSIONE

Modello macchina	PEGASUS 38.16 - 400°	PEGASUS 40.18 - 400°
Tipo trasmissione	Idrostatica con pompa a portata variabile	Idrostatica con pompa a portata variabile
Motore idraulico	Idrostatico a variazione automatica continua	Idrostatico a variazione automatica continua
Inversione	Elettro-Idraulica	Elettro-Idraulica
Inching	A pedale idraulico per avanzamento controllato	A pedale idraulico per avanzamento controllato
Cambio	A 2 velocità servocomandato	A 2 velocità servocomandato

## PNEUMATICI

Modello macchina	PEGASUS 38.16 - 400°	PEGASUS 40.18 - 400°
Pneumatici standard	400/70x20"	400/70x20"
Pneumatici optional	400/70R20"	400/70R20"

## DIMENSIONI

Modello macchina	PEGASUS 38.16 - 400°	PEGASUS 40.18 - 400°
A	310 mm (12,2 in)	310 mm (12,2 in)
B	2430 mm (95,7 in)	2280 mm (89,8 in)
C	2950 mm (116,1 in)	2950 mm (116,1 in)
D	1175 mm (46,3 in)	1175 mm (46,3 in)
E	1490 mm (58,7 in)	1330 mm (52,4 in)
F	4880 mm (192,1 in)	4880 mm (192,1 in)
G	6740 mm (265,4 in)	6630 mm (261 in)
H	3035 mm (119,5 in)	3035 mm (119,5 in)
I	980 mm (38,6 in)	980 mm (38,6 in)
L	1920 mm (75,6 in)	1920 mm (75,6 in)
M	2380 mm (93,7 in)	2380 mm (93,7 in)
N	3968 mm (156,2 in)	3968 mm (156,2 in)
O	5163 mm (203,3 in)	5163 mm (203,3 in)
P	1700 mm (66,9 in)	1700 mm (66,9 in)
Q	4430 mm (174,4 in)	4430 mm (174,4 in)
R	4750 mm (187 in)	4750 mm (187 in)
S	2420 mm (95,3 in)	2420 mm (95,3 in)
T	200 mm (7,9 in)	140 mm (5,5 in)

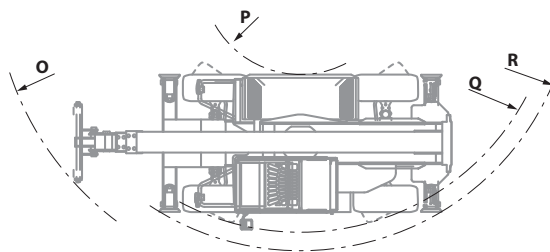
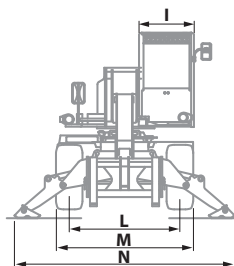
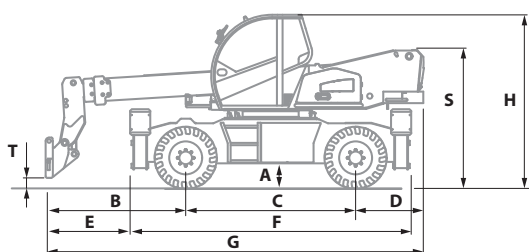

MAX 2,3 t

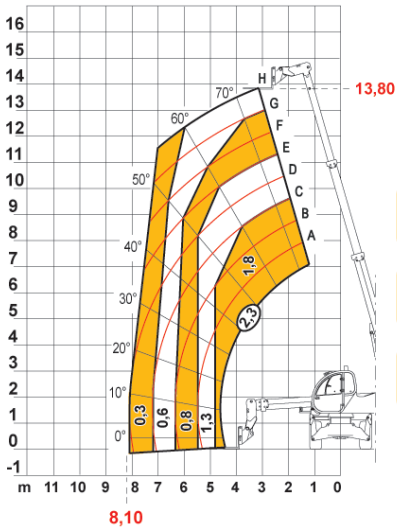

AXBI487



EN1459

38.16 - 400°

MAX 1,8 t

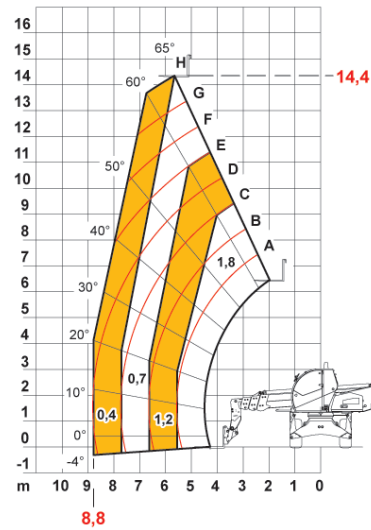

AXBI508



EN1459

40.18 - 400°

MAX 3,8 t

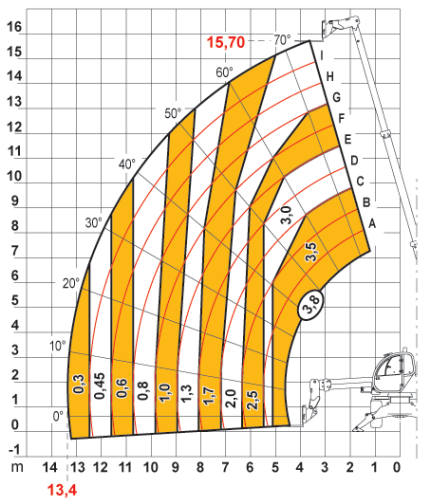

AXBI487-I



EN1459

38.16 - 400°

MAX 4,0 t

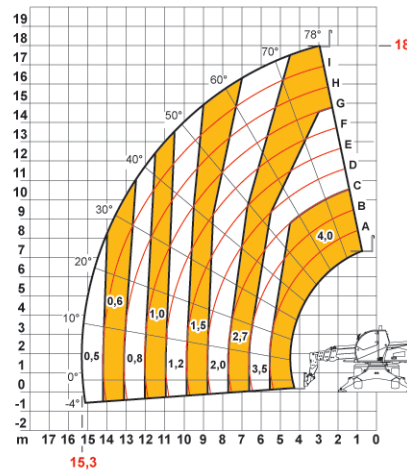

AXBI508/I



EN1459

40.18 - 400°

MAX 3,2 t

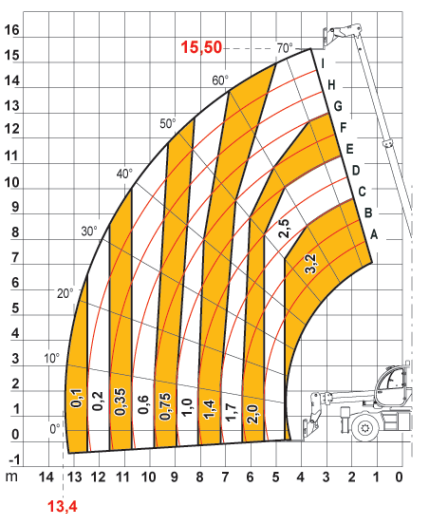

AXBI487-I2



EN1459

38.16 - 400°

MAX 3,5 t

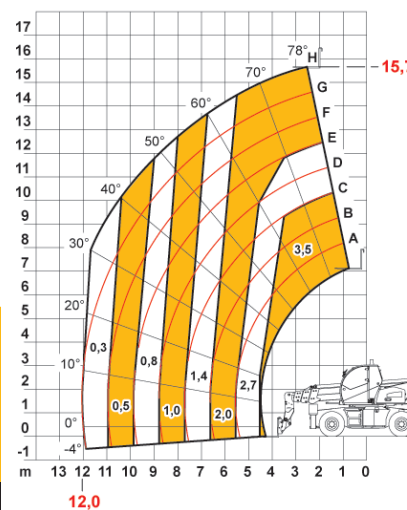

AXBI508/I2



EN1459

40.18 - 400°